

Pioneering for You

*Equipment for sewage disposal and treatment.*

## Sewage and Submersible Pumps

FA, Rexa PRO, MTS



**Wilo**

Pioneering for You.



USA Manufacturing  
Thomasville, Georgia

Same Products  
New **Color**



**EMU**

**wilo**

>> German  
Engineering

>> American  
Manufacturing

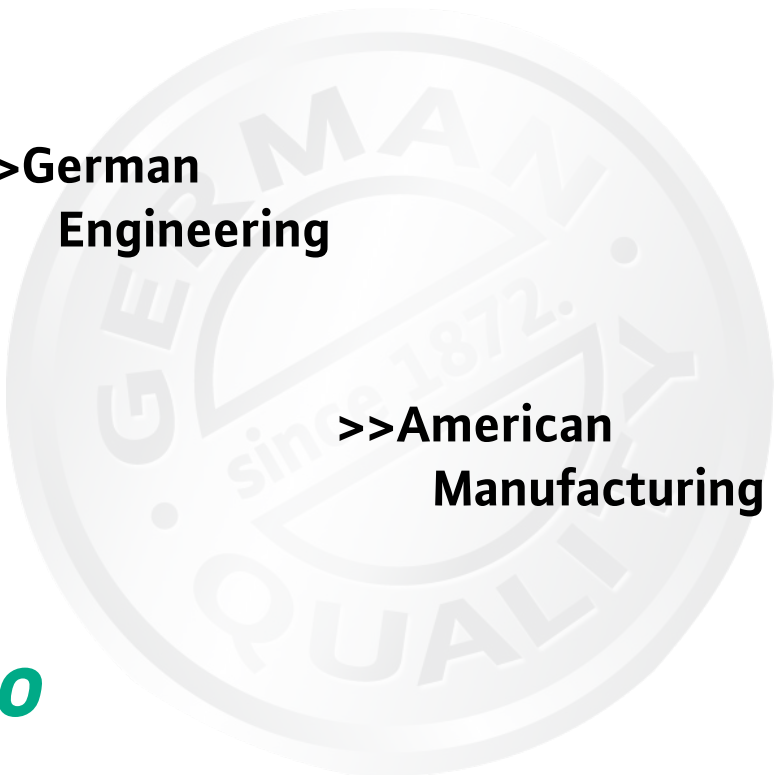

## Wilo FA

### Submersible Sewage Pump

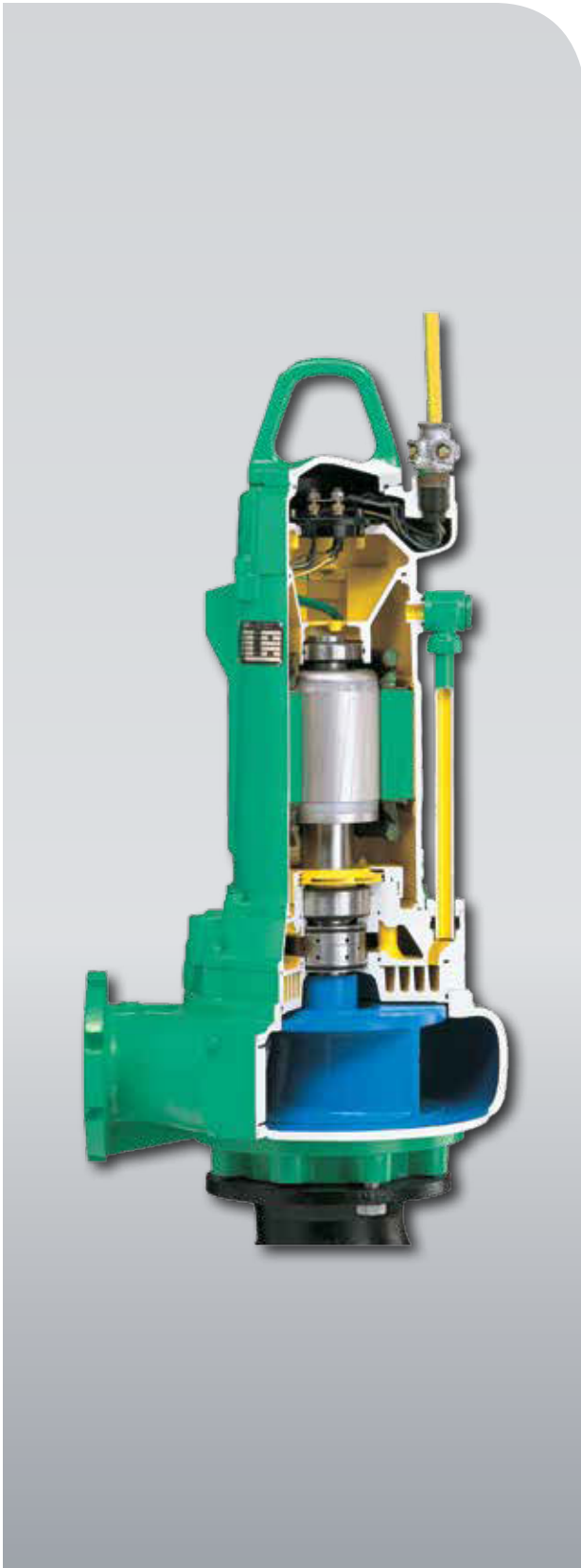

#### Enclosed Block Seal

- Durable and long life
- Stainless steel construction
- Compact design for low overhang
- Dual silicon carbide seal faces (70 HRB)



#### Cooling System

Highly efficient - closed loop with heat exchanger.



#### The Wilo Difference

Largest diameter shafts with lowest overhangs in the industry for maximum pump life!

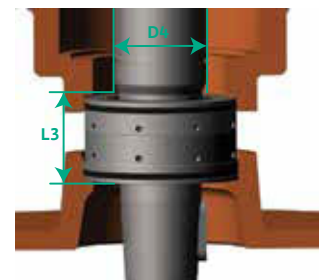

***5 year limited warranty***

# Wilo FA

## Submersible Sewage Pump

### Applications:

- Sewage Collection
- Storm Water
- Raw Water
- Sewage Treatment
- Dewatering
- Industry

### Size

- Discharge: 2"-24"
- HP: ¼-1000
- Max Flow: 40,000 USGPM
- Max TDH: 420 feet

### Features & Benefits

- Portable, wet well or dry well installation
- Short overhang & large diameter shafts for lowest  $L^3/D^4$  shaft bending ratio in industry
- Special Ceram® ceramic coatings
- Special materials: stainless steel, high chrome cast iron, ductile cast iron

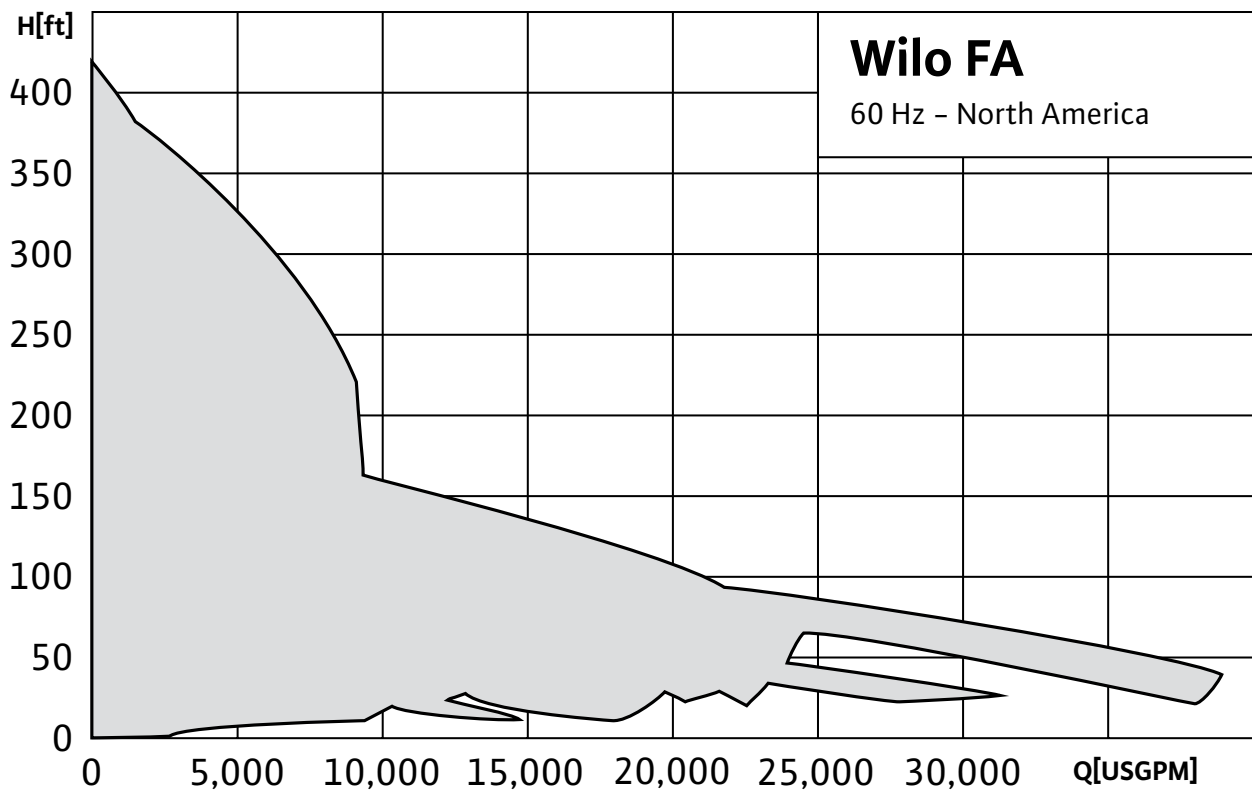

# Wilco Impellers

An option for every application

## Features & Benefits

- **Handles flushable wipes, fibrous solids and rags!**
- Solids passage of a vortex impeller with the efficiency of an enclosed non clog impeller
- Impeller trimmed to specific duty point
- Free passage: 3x4 - 7x7 in (78x105 - 170x170 mm)

Alternative impellers available.

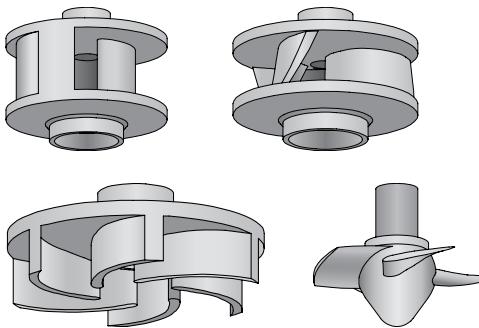

**SOLID**

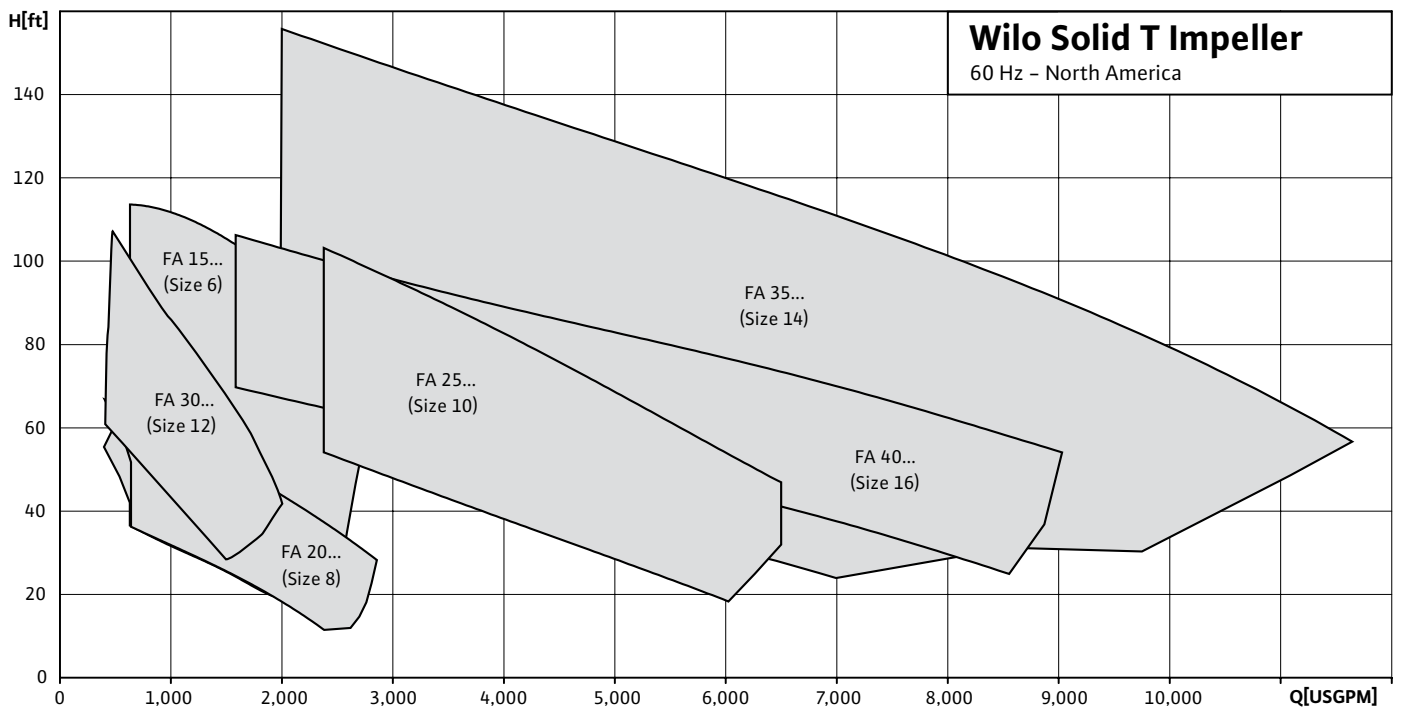

# Wilo Rexa PRO

## Submersible Sewage Pump

### Applications:

- Wastewater and sewage
- Drainage
- Sludges up to 8%
- Municipal and industrial applications

### Size

- Discharge: 2"-3"
- HP: 1½-5
- Max Flow: 500 USGPM
- Max TDH: 100 feet

### Features & Benefits

- Available voltages: 208v-575v
- Clog-resistant vortex impeller
- Dual mechanical shaft seals
- Heavy-duty cast iron construction

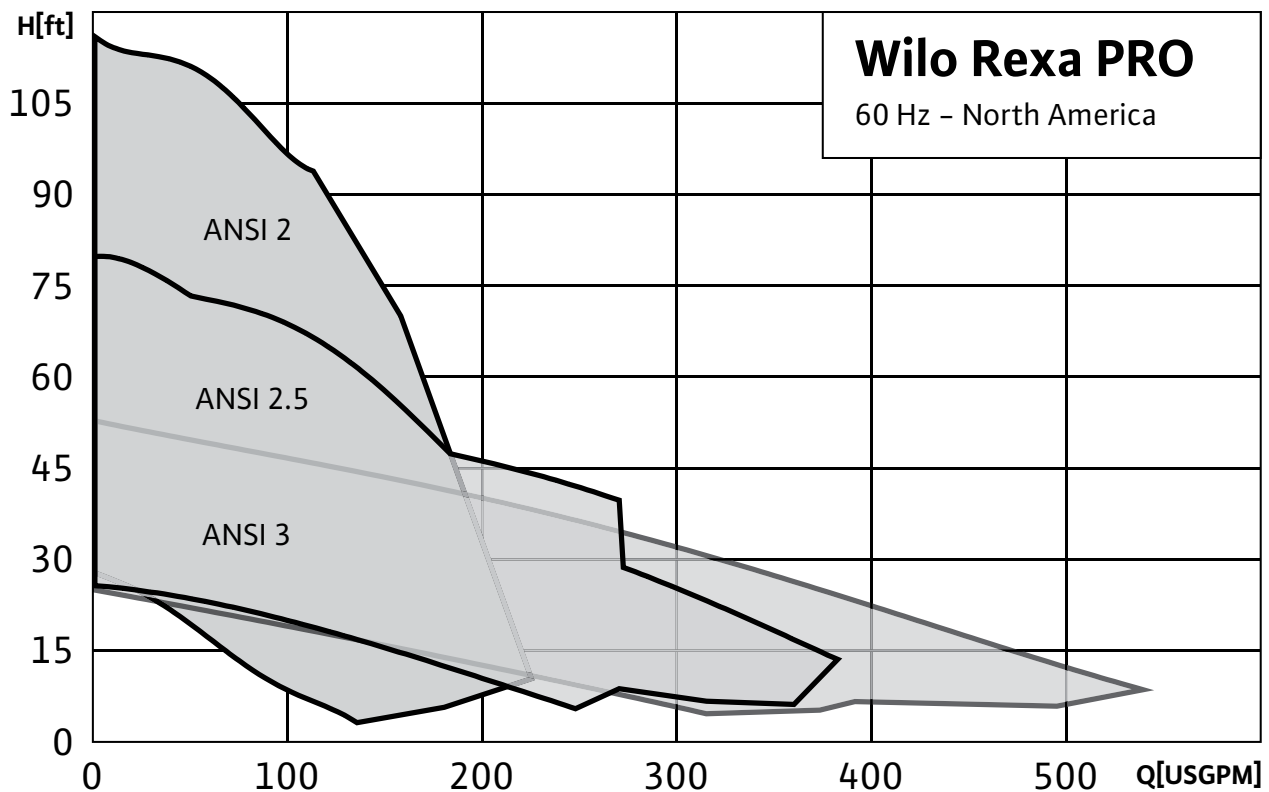

## Wilo MTS

### Submersible Sewage Pump with Grinder

#### Applications:

- Solids Grinder
- High Pressure Sewer
- Draining
- Wastewater Treatment

#### Size

- Discharge: 1¼" NPT / 2" Flange
- HP: 2-5.4
- Max Flow: 80 USGPM
- Max TDH: 160 feet

#### Features & Benefits

- Scissor-style cutter
- Cast iron volute
- Hardened stainless steel cutting mechanism

**Patented Macerator Design**  
**Virtually Eliminates Clogging!**

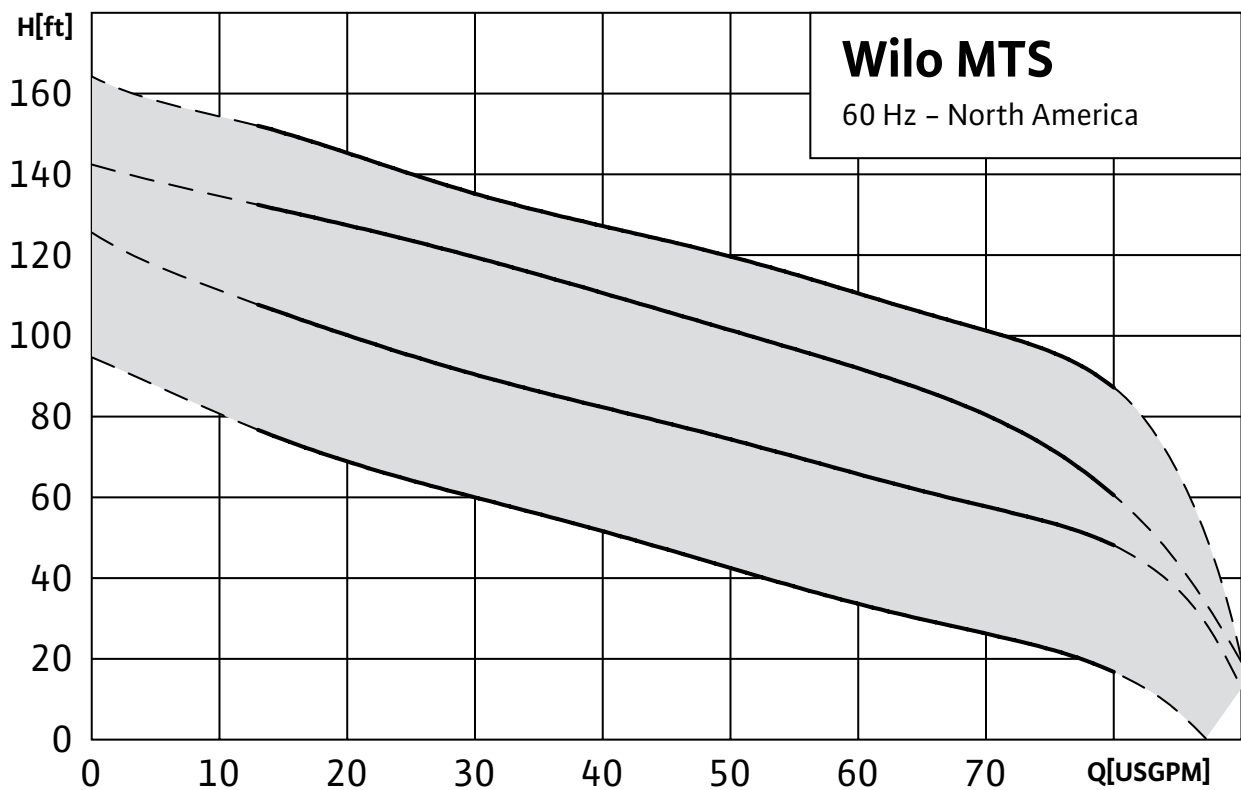



10-I-002-0516

**WILO USA LLC**

888-945-6872  
[www.wilo-usa.com](http://www.wilo-usa.com)  
[info@wilo-usa.com](mailto:info@wilo-usa.com)

**WILO Canada Inc.**

866-945-6236  
[www.wilo-canada.com](http://www.wilo-canada.com)  
[info@wilo-canada.com](mailto:info@wilo-canada.com)

**WILO Mexico**

+52 55 5586 3209  
[www.wilo-mx.com](http://www.wilo-mx.com)  
[info@wilo.com.mx](mailto:info@wilo.com.mx)